



DUTYPOINT.COM

# CXC DIRT AND AIR SEPARATORS



# CX Range

**Designed to automatically  
remove dirt and air from  
heating, cooling and  
process systems.**

## PRODUCT OVERVIEW

- We offer six different standard configurations in a multitude of sizes from DN50 to DN300 as standard

# Key Features

RANGE OF CONFIGURATIONS AND SIZES TO MEET SPECIFIC APPLICATION REQUIREMENTS



HIGH-EFFICIENCY STAINLESS STEEL INTERNAL STRAINER

HIGH-QUALITY CARBON STEEL CONSTRUCTION

# Specification

The Dutypoint CX range of separators automatically removes dirt and air from heating, cooling and process systems, ensuring optimum performance of your equipment at all times. These should be installed in all new buildings and can be retrofitted into existing systems to provide economic and environmental benefits. In addition, separators should be installed in any sizeable open or closed-loop system, including chilled water systems, condenser water systems and process water systems.

We offer six different standard configurations in a multitude of sizes to ensure we can provide the best solution for your application.

## CXC DIRT AND AIR SEPARATOR

- Combined units used in pipelines to efficiently remove air, microbubbles and particles.

## CXC-RE DIRT AND AIR SEPARATOR WITH REMOVABLE ELEMENT

- Same as the CXC but includes a removable flange to facilitate easy cleaning and maintenance.

## CXP DIRT SEPARATOR

- Used in pipelines to remove impurities and particles.

## CXP-RE DIRT SEPARATOR WITH REMOVABLE ELEMENT

- Same as the CXP but with a removable flange to facilitate easy cleaning and maintenance.

## CXA AIR SEPARATOR

- Used in pipelines to remove air and microbubbles.

## CXX BALANCING TANK WITH DIRT AND AIR SEPARATOR

- A combination of the above units, plus facilitating proper mixing to keep the flow in the boiler and distribution circuits the same, providing optimum hydronic balance.

## SEPARATOR SPECIFICATION

Body	Carbon steel – ST 37
Max system pressure	10 bar
Max system temperature	110°C
Internal element	AISI 304 stainless steel

## AUTOMATIC AIR VENT SPECIFICATION

Body	Brass
Connections	Screwed
Max system pressure	10 bar
Max system temperature	110°C
Float	Polypropylene

All units are designed and manufactured in accordance with Pressure Equipment Directive 97/23/EC, 1997. Larger units up to DN600 are available to order.



# CXC - Combined Dirt and Air Separators

Dutypoint CXC combined dirt and air separators can be used instead of individual deaerators and dirt separators.

These combined units are very efficient and extremely cost effective, becoming the preferred standard option throughout the industry. In heating systems, the units should be installed in the flow loop, situated immediately after the boiler and prior to the pump. In a chilled water system, the unit must be located in the return loop close to the chiller.

The efficiency of the unit will be reduced if the system static head exceeds 15 m and system flow velocity exceeds 3 m/s.

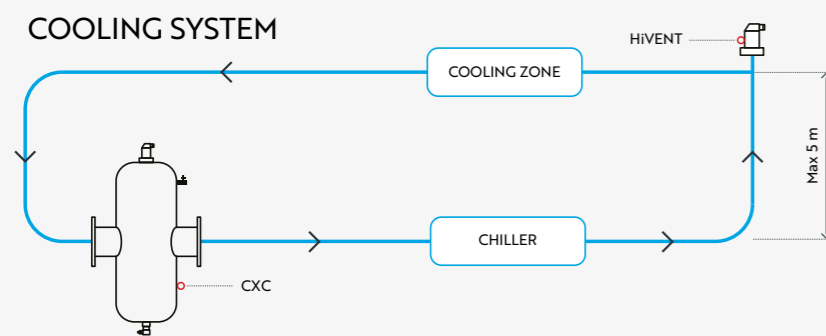
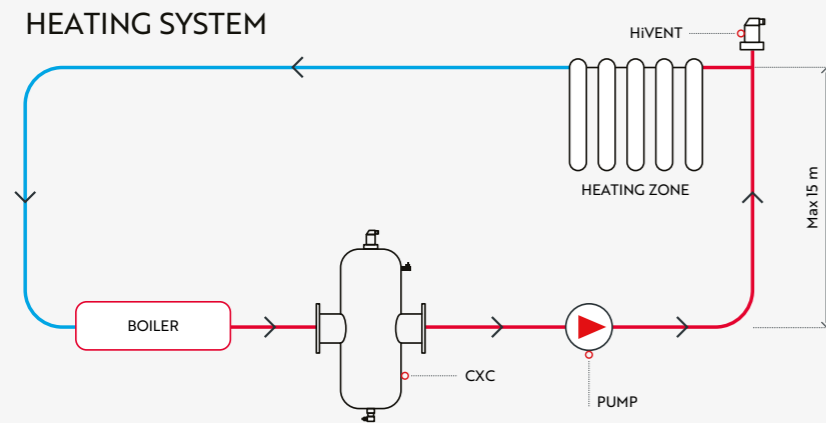

## STANDARD TECHNICAL FEATURES

- Efficient removal of air and microbubbles in pipework
- Effective removal of impurities and particles
- Stainless steel element
- Designed and manufactured in accordance with the Pressure Equipment Directive 97/23/EC

## OPTIONS

- Removable element (CXC-RE)
- Larger units up to DN600 available on request
- Non-standard connections

## NOTE

- The static head must not exceed 15 m for a heating system and 5 m for a cooling system

# CXC/CXC-RE

## DRAWINGS AND DIMENSIONS

Model no.	Flow rate (m <sup>3</sup> /h)	Volume (litres)	Weight (kg)	Dimensions					
				DN (mm)	OD (mm)	A (mm)	B (mm)	C (inches)	H (mm)
<b>CXC combined dirt and air separators</b>									
CX50C	8	7	17	50	60	265	350	1"	632
CX65C	15	7	18	65	76	265	350	1"	632
CX80C	20	25	38	80	88	345	470	1"	791
CX100C	30	25	40	100	114	345	475	1"	791
CX125C	50	75	62	125	139	480	635	1"	1064
CX150C	75	75	67	150	168	480	635	1"	1064
CX200C	125	150	150	200	219	615	775	1"	1307
CX250C	200	300	300	250	273	815	890	2"	1568
CX300C	275	500	545	300	323	970	1005	2"	1892
<b>CXC-RE combined dirt and air separators with removable element</b>									
CX50C-RE	8	7	37	50	60	265	350	1"	632
CX65C-RE	15	7	38	65	76	265	350	1"	632
CX80C-RE	20	25	61	80	88	345	470	1"	791
CX100C-RE	30	25	63	100	114	345	475	1"	791
CX125C-RE	50	75	102	125	139	480	635	1"	1064
CX150C-RE	75	75	107	150	168	480	635	1"	1064
CX200C-RE	125	150	207	200	219	615	775	1"	1307
CX250C-RE	200	300	373	250	273	815	890	2"	1568
CX300C-RE	275	500	624	300	323	970	1005	2"	1892

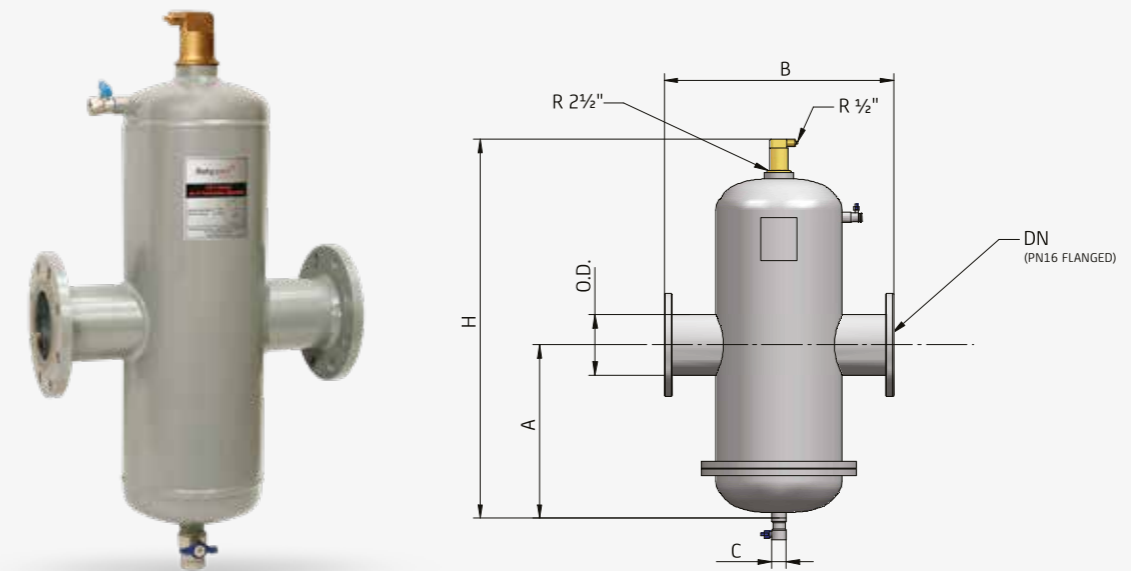



**Let's talk about CXC  
dirt and air separators**

01452 300110

ENQUIRIES@DUTYPOINT.COM

DUTYPOINT.COM